

TONE/PULSE SWITCHABLE DIALER WITH LCD INTERFACE AND DUAL-TONE MELODY

DESCRIPTION

The SC91415 is a series of tone/pulse switchable dialers that is composed of T/P dialer and T/P dialer with 13 set memories. The SC91415 series provide necessary functions of telephone set for application in any environment, such as Pulse dialing, Tone (DTMF) dialing, Handfree dialing, keying tone and lock functions. The lock function is designed to inhibit toll dialing operation. Beside this, melody generator, ring detector and SDO (Serial Data Output) functions are provided in advance version. Melody generator will output dual-tone music in line hold duration. Ring detector can prevent illegal dialing from pocket dialer. The SDO is designed to drive LCD driver and voice synthesizer.

FEATURES

- *Tone/Pulse switchable
- *Wide operating voltage from 2.0 V to 5.5 V
- *Low operating current, 0.15mA (Pulse) and 0.3mA (Tone) typically
- *Adding resistor on keyboard scan pin that can select many telephone specifications, such as: Pulse rate, M/B ratio, Flash time, lock dialing functions.
- *Lock function provides conventionality key lock and password lock operations
- *Ring detector is designed to prevent illegal dialing from pocket dialer
- *13 set one touch or (3 set one touch and 10 set two touch) repertory memory, each one can hold data up to 16 digits
- *A 32-digit LNB (last number) redial memory
- *Handfree function provides on-hook dialing and speakerphone application
- *Pause and P-T time are fixed to 3.6 seconds
- *Tone duration and inter-tone pause time are fixed to 98 ms
- *Using 3.579545 MHz crystal or ceramic resonator
- *SDO function supports LCD driver and voice synthesizer to indicate dialing numbers.
- *Line hold function is designed for stopping conversation temporality
- *Melody generator provides music on hold function
- *Keytone function provides rapidly keying recognition

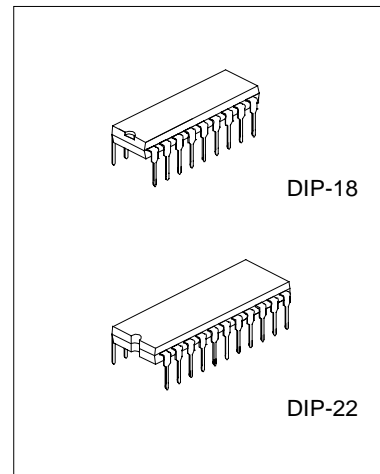

ORDERING INFORMATION

SC91415AP	DIP-18 Package
SC91415BP	DIP-20 Package
SC91415CK	DIP-22 Package
SC91415DK	DIP-24 Package

PIN CONFIGURATIONS

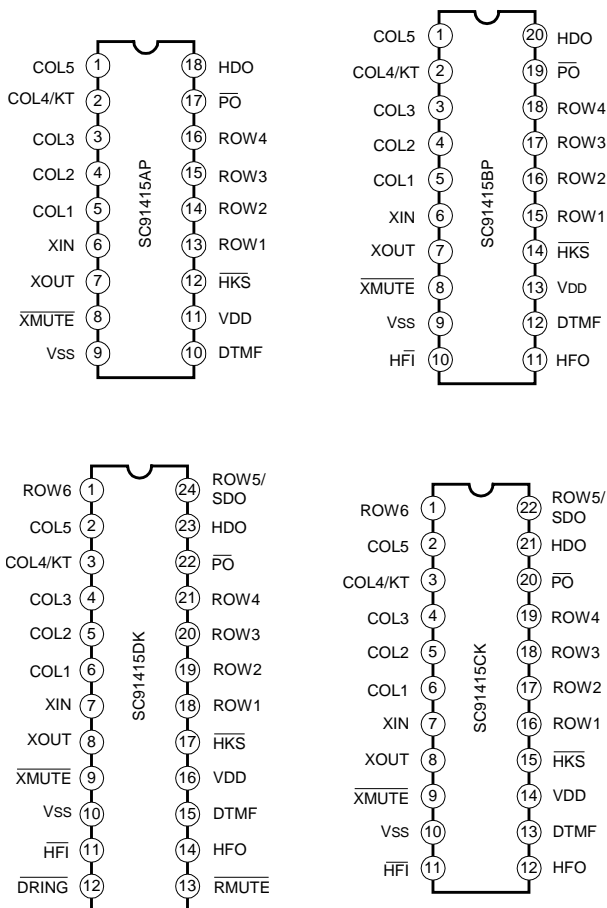

VERSIONS LIST AND FUNCTION OUTLINE

Version	LNB	KT	HOLD(music)	LOCK	HF	SDO(LCD)	PDP
SC91415A	✓	✓	✓	✓			
SC91415B	✓	✓	✓	✓	✓		
SC91415C	✓	✓	✓	✓	✓	✓	
SC91415D	✓	✓	✓	✓	✓	✓	✓

Note: PDP = Pocket Dialer Prevented

BLOCK DIAGRAM

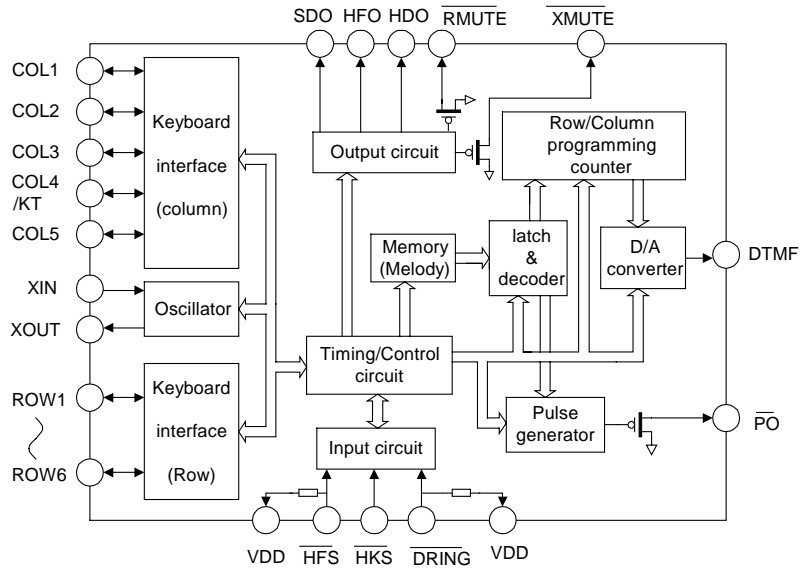

KEYBOARD ASSIGNMENT

	COL1	COL2	COL3	COL4/KT	COL5
ROW1	1	2	3	HD	EM1
ROW2	4	5	6	F	EM2
ROW3	7	8	9	A	EM3
ROW4	*/T	0	#	RD/P	ST
ROW5/SDO	M1	M2	M3	M4	M5
ROW6	M6	M7	M8	M9	M10

Note: ROW5/SDO: Option by COL5, When ROW5 is selected by R option (COL5), there are 13 sets one touch memory version in SC91415C/D provided.

DIALING SIGNAL OPTION

The SC91415 series incorporated a special keyboard scanning function that is connecting a resistor (typically is 560 kΩ) on keyboard scan pin to select many telephone specifications. The specifications are described as following :

a. Mode

ROW1	Mode
R-VDD	20PPS
NR	Tone
R-Vss	10PPS

b. M/B ratio

ROW2	MBR (%)
NR	40:60
R-Vss	33:66

c. Flash Time

ROW3	ROW4	Tf (ms)
NR	NR	600
NR	R-Vss	100
R-Vss	NR	80
R-Vss	R-Vss	300

d. Lock control method

COL1	Control method
R-VDD	Key lock
NR	None lock
R-Vss	Password lock

e. Lock number

COL2	COL3	Lock number
NR	NR	None
NR	R-Vss	0
R-Vss	NR	9
R-Vss	R-Vss	0.9

f. ROW5/SDO pin functions

COL5	ROW5 or SDO Pin
NR	SDO
R-Vss	ROW5

(Note): If select SDO function, the memory type is

(1T*3+2T*10)

If select ROW function, the memory type is

(1T*3+2T*10) and (1T*13)

ABSOLUTE MAXIMUM RATINGS

(Tamb=25°C, All voltage referenced to VSS, unless otherwise specified)

Characteristic	Symbol	Value	Unit
Power Supply Voltage	VDD	6.0	V
Input Voltage	VIN	VSS-0.3~VDD+0.3	V
Power Dissipation	PD	500	mW
Operating Temperature	Topr	0~+50	°C
Storage Temperature	Tstg	-55~+125	°C

ELECTRICAL CHARACTERISTICS

(Tamb=25°C, VDD=2.5V, fosc=3.579545MHz, All voltage referenced to VSS, unless otherwise specified)

Parameter	Symbol	Test Conditions	Min	Typ	Max	Unit	
Operating Voltage	VDD	Tone	unload	2.0	--	5.5	V
		Pulse		2.0	--	5.5	
Operating Current ($\overline{HKS}=0$)	IDD	Pulse	Unload	--	0.15	0.3	mA
		Tone		--	0.3	0.5	
		Pulse	with pull up/down resistor *8	--	0.15	0.3	
		Tone		--	0.3	0.5	
Standby Current	Istby	ON-HOOK	Unload				
		OFF-HOOK					
		ON-HOOK	with pull up/down resistor *8				
		OFF-HOOK		--	0.1	1.0	
Memory Retention Current	Imrt	ON-HOOK, VDD=1.0V	--	0.001	0.1	μA	
\overline{HKS} , \overline{HFI} & DRING pins: Input Voltage	Vil	--	VSS		0.2VDD	V	
	Vih	--	0.8VDD		VDD		
HFO & HDO Pins Source Current	Ioh	Vo=2.0V	0.2	--	--	mA	
\overline{PO} , \overline{XMUTE} , \overline{RMUTE} & SDO Pins Leakage Current	Ioh	Vo= VDD	--	--	±0.001	μA	
\overline{PO} , HFO, \overline{XMUTE} , \overline{RMUTE} & SDO Pins Sink Current	Iol	Vo=0.5V	-0.2	--	--	mA	
\overline{DRING} pin input resistance	Rdring	Vdring = VSS	--	100	--	kΩ	
\overline{HFI} Pin Input Resistance	Rhfi	Vhfi = VSS	--	200	--	kΩ	
Keyboard Scanning Pins Output Current(except COL4/KT)	Ioh	Vksn=VSS	2	10	50	μA	
	Iol	Vksn=VDD	2	10	50		
COL4/KT Source Current Sink Current	Ioh	Vo=2.0V	0.2	--	--	mA	
	Iol	Vo=0.5V	0.2	--	--		
Keyboard debounce time	Tdb	--	--	20	--	ms	
Key Tone Signal	Frequency	fkt	--	600	--	Hz	
	Duration	Tkt	--	30	--	ms	
Pause Time	Tp	--	--	3.6	--	Sec.	
Pulse to Tone Waiting Time	Tpt	--	--	3.6	--	Sec.	
Flash Time	Tf	Row3B, Row4B=NR,NR	--	600	--	ms	
		Row3B, Row4B=NR,R-Vss		100			
		Row3B, Row4B=R-Vss,NR		80			
		Row3B, Row4B=R-Vss,R-Vss	--	300	--		

(to be continued)

(continued)

Parameter		Symbol	Test Conditions	Min	Typ	Max	Unit
Pulse Rate		PSR	Row1=R-VDD	--	20	--	pps
			Row1=R-VSS	--	10	--	
Make/Break Ratio		MBR	Row2=NR	--	40:60	--	%
			Row2=R-VSS	--	33:66	--	
Inter-digit Pause Time		T _{idp}	PSR=10pps	--	800	--	ms
			PSR=20pps	--	500	--	
DTMF pin: Sink Current		I _{oL}	V _{dtmf} =0.5V	-0.2	--	--	mA
DTMF signal DC level		V _{dc}	VDD=2.0V~5.5V	0.5	--	0.75	V
DTMF signal	AC Level	V _{dtmf}	Row group	142	160	180	mV
	Pre-emphase	T _{wist}	Column – Row	1	2	3	dB
	Distortion	THD	RL=5kΩ	--	-30	-23	dB
	Load Resistance	ZL	THD<-23db	5	--	--	kΩ
Minimum tone duration Time		T _p	--	96	98	100	ms
Minimum Intertone Pause Time		t _{IPT}	Memory dialing	96	98	100	ms
Melody Output Signal	Main Tone AC Level	V _{mtac}	VDD=2.0V~5.5V	--	-23.3	--	(dBm)
				48	53	58	mV
Sub-tone		V _{stac}	VDD=2.0V~5.5V	--	-25.3	--	(dBm)
				37	42	47	mV
HD key release hold function debounce time		T _{hdrdb}	--	--	280	--	ms
SDO every bit time		T _{bit}	--	3.8	3.9	4.1	ms
Off-Hook delay time		T _{dly}	--	--	300	--	ms

DTMF FREQUENCY OUTPUT (f_{osc}=3.579545MHz)

Keyboard Scanning Pin	CCITT Standard(Hz)	Actual Output	Deviation(%)
ROW1 (f1)	697	699.1	+0.30
ROW2 (f2)	770	766.2	-0.49
ROW3 (f3)	852	847.4	-0.53
ROW4 (f4)	941	947.9	+0.73
COL1 (f5)	1209	1215.8	+0.56
COL2 (f6)	1336	1331.6	-0.32
COL3 (f7)	1477	1471.8	-0.35

PIN DESCRIPTION

Pin No.				Pin Name	Description
AP	BP	CK	DK		
13	15	16	18	ROW1	Keyboard scan pins of row group. In idle state ($\overline{\text{HKS}}$ is "High" and HFO is "Low"), these pins stay "High impedance" level to prevent power consumption. Otherwise, these pins switch to "High" level for detecting keyboard entry. These pins will output 600Hz signal while keyboard is scanning.
14	16	17	19	ROW2	
15	17	18	20	ROW3	
16	18	19	21	ROW4	
--	--	22	24	ROW5	
--	--	1	1	ROW6	
5	5	6	6	COL1	Keyboard scan pins of column group. In idle state, these pins stay "High impedance" level. Otherwise these pins switch to "Low" level for detecting keyboard entry. These pins will output 600Hz signal while keyboard is scanning.
4	4	5	5	COL2	
3	3	4	4	COL3	
1	1	2	2	COL5	
2	2	3	3	COL4/KT	The fourth column group pin of the keyboard that also provides the keytone output. Normally, this pin stays "Low" level for detecting keyboard entry. After a valid keyboard entry, this pin will output keying confirmation tone that is 600 Hz signal and 30 ms duration. To prevent signal interference, while DTMF issue, it will disable key tone output except function key.
6	6	7	7	XIN	Oscillator input and output pins. A 3.579545MHz crystal or ceramic resonator must be crossed connection to XIN and XOUT pins which generate system clock.
7	7	8	8	XOUT	
8	8	9	9	$\overline{\text{XMUTE}}$	The Tone/Pulse MUTE signal output pin that is NMOS open-drain output structure. This pin will switch to "Low" level during Tone/Pulse dialing and hold function. Otherwise, this pin stays "High impedance" level.
11	13	14	16	VDD	Positive and negative power supply input pins. Recommended operating voltage from 2.0Vdc to 5.5Vdc.
9	9	10	10	VSS	
--	10	11	11	$\overline{\text{HFI}}$	Handfree inputs pin which accepts falling edge signal to turn "on" or turn "off" handfree function. This pin is hysteresis input structure and built-in pull up resistor (typically 200k Ω).
--	11	12	14	HFO	Handfree outputs pin that is designed to control telephone line for on-hook dialing or control speakerphone circuit for handfree conversation. When handfree function is executed, this pin will switch to "High". Otherwise, this pin stays "Low" level.
10	12	13	15	DTMF	The DTMF (Dual Tone Multi-Frequency) and music signals output pin. Normally, this pin stays "Low" level. In Tone dialing mode, this pin will output DTMF signal that is corresponding to keyboard 0 . 9, * and # keys. Beside this, in the line hold duration, this pin will issue dual-tone music for telephone line.

(to be continued)

(continued)

Pin No.				Pin Name	Description
AP	BP	CK	DK		
12	14	15	17	$\overline{\text{HKS}}$	Control signal inputs pin that is corresponding hook switch status. When handset was left from cradle, this pin must be connected to "Low" level to operate all functions. Otherwise, this pin must be connected to "High" level to disable all function and prevent power consumption.
17	19	20	22	$\overline{\text{PO}}$	Pulse signal outputs pin that is NMOS open-drain output structure. Normally, this pin stays "High impedance" level. In Pulse dialing mode and keypad was entry. This pin will output pulse trains signal that is corresponding to keyboard 0 .. 9 keys.
18	20	21	23	HDO	Hold function output that is CMOS structure. Normally, this pin stays "Low" level. When Hold function is executing, this pin will output "High" level. This pin is designed to drive LED or peripheral circuit to indicate line is at Hold status.
--	--	22	24	SDO	SDO function output that is NMOS open-drain structure. When there is a valid entry on keyboard, this pin will output a serial data. This serial data is designed to drive LCD driver to display dialing number on LCD screen or drive voice synthesizer to announce dialing number to speaker.
--	--	--	12	$\overline{\text{DRING}}$	The ring signal detect input pin which is internal pull up (built-in 100 k Ω resistor). While the Tel-ring is incoming, this pin must be connected to "Low" with delay to indicate the ringing . Otherwise, this pin must be connected to "High" level .
--	--	--	13	$\overline{\text{RMUTE}}$	Ring mute output pin that is NMOS open-drain structure. The $\overline{\text{RMUTE}}$ pin is designed to control microphone of handset to prevent the illegal dialing from pocket dialer. If the $\overline{\text{DRING}}$ pin is at "High" level , then Off-Hook or turn on Handfree, this pin will output "Low" level. In other words, the $\overline{\text{DRING}}$ pin is used to check the phone that receives an incoming call ($\overline{\text{DRING}}$ =Low input) or make an outgoing call ($\overline{\text{DRING}}$ = High input) . If the phone user make an outgoing call ,then $\overline{\text{RMUTE}}$ pin activated to prevent the illegal dialing from pocket dialer in the particular application. The $\overline{\text{RMUTE}}$ can be restored to "High" level when the first key entry is not the optioned lock-number .

FUNCTION DESCRIPTIONS**A) Normal Dialing**

Directly keying digital key on keyboard which number can be dialing output and stored in LNB memory automatically.

Operating procedure described as follow :

- * To select Pulse or Tone mode.
- * Off-hook or turn on HF function.
- * Keying d1, d2, .. , dn. The "d" expressed digital keypad that included 1~9, *, 0, #, P, and P→T keys. The "n" expressed unlimited.
- * The numbers d1, d2, .. , dn will be dialed out in Pulse or Tone mode as selection.

B) LNB redial memory

Storing:

In normal dialing mode, every digital key was entry which number will be stored in LNB memory automatically. If entry digits are more than 32 digits, the redial function of LNB memory will be disabled. Otherwise, these numbers stored in LNB memory can be redial output.

Redialing:

After normal dialing, directly keying F key (or On-Off hook once) and keying RD key on keyboard. The numbers that are stored into LNB memory will be dialed output.

C) Repertory memory

The SC91415 series incorporated several sets repertory memory and each one can store number up to 16 digits. In memory storing, if stored numbers are more than 16 digits that only the previous 16 digits can be stored into specific memory. Otherwise, these numbers can be stored entirely. After memory dialed out, the content of LNB is keeping to current data.

Storing of 13 sets memory types

Direct (one-touch) operation

Off-hook (or turn on HF function), push (ST, d1, d2, .. , dn [ST], EMn or M1~M10 (ROW5 optioned). The numbers d1, d2, .. , dn will be stored into memory location "EMn" or Mn. The "EMn" expressed emergency memory EM1 to EM3. The Mn expressed memory M1~M10.

Indirect (two-touch) memory operation

Off-hook (or turn on HF function), push (ST, d1, d2, .. , dn, ST, n.) The numbers d1, d2, .. , dn will be stored into memory location "n". The "n" expressed digital key from 0 to 9.

Dialing (after memory dialed out, the content of LNB is keeping to current data)

Direct (one-touch) memory operation

* To select Pulse or Tone mode.

* Off-hook (or Turn on HF function), push Mn (or EMn) key. The numbers that are stored in direct memory location "Mn (or EMn)" will be dialed out in Pulse or Tone mode as selection. The "n" expressed digital number from 1~10 decided by dialers' memory sets.

Indirect (two-touch) memory operation

* To select Pulse or Tone mode.

* Off-hook (or Turn on HF function), push A, n key. The numbers that are stored in indirect memory location "n" will be dialed out in Pulse or Tone mode as selection. The "n" expressed digital key from 0 to 9.

Pause (P) Key operation

The Pause (P) key is designed to support pause operation in dialing duration. "P" key can be stored in memory and it will occupy one digital position.

* To select Pulse or Tone mode.

* Off-hook (or turn on HF function), push (d1, d2, .. , dn, RD/P, k1, k2, .. , kn.) These numbers will be dialed out as following sequence:

d1, d2, .. , dn, Tp, k1, k2, .. , kn

Pulse to Tone (*T) key operation

The Pulse to Tone (*T) key is designed to support toll dialing (long distance call) or PABX system operation. The "*T" key can be stored in memory and it will occupy one digital position.

* To select Pulse mode.

* Off-hook (or turn on HF function), push d1, d2, .. , dn, *T, k1, k2, .. , kn. These numbers will be dialed out as following sequence:

d1, d2, .. , dn, Tpt, k1, k2, .. , kn.
(pulse mode) (tone mode)

Flash (F) key operation

The Flash (F) key is designed to break telephone line temporarily. After F key is depressed, this dialer will send a flash signal to break line 600 ms, 300 ms, 100 ms or 80 ms as ROW3 and ROW4 selection.

D) Handfree (HF) function

The handfree function is designed to support on-hook dialing and loudspeaker application which can be turn “on” or “off” with falling edge signal from $\overline{\text{HF1}}$ pin. During handfree function is executed, the HFO pin is switched to “high”. Otherwise the HFO pin stays “low” level. One of the following operations can turn off Handfree function (HFO pin return to “Low”).

- * On-off hook once.
- * Trigger $\overline{\text{HF1}}$ pin with falling edge signal.
- * Turn on Hold (HD) function. (HDO pin switched to “High”)

E) Hold (HD) function

The Hold function is designed to stop conversation temporarily. In off-hook state (or HF function is turned on), to press HD key on the keyboard, the Hold function can be turned “on” (HDO pin switched to “High”). One of the following operations can turn off Hold function (HDO pin switched to “Low”).

- * On-off hook once.
- * To press HD key over 280 ms.
- * Turn on Handfree (HF) function. (HFO pin switched to “High”)

Special Note

A 300 ms delay time (T_{dly}) at the first Off-Hook or turn on Handfree that is a special designed to avoid a rapid key entry (dummy number) in this time duration, and a long distance call number follows. For example,

Off-Hook, “3”, , “0”, 1,2,3.....

Dummy key Lock number key

The dummy number “3” is not detected by the centered office or PABX, but the following numbers “0”, 1,2,3... long distance call can be dialed out normally since the leading number “3” is not the Lock-number defined in SC91415 series. To prevent the unavoidable long distance call, then SC91415 inhibits the key entry during T_{dly}.

F) Operating flow chart

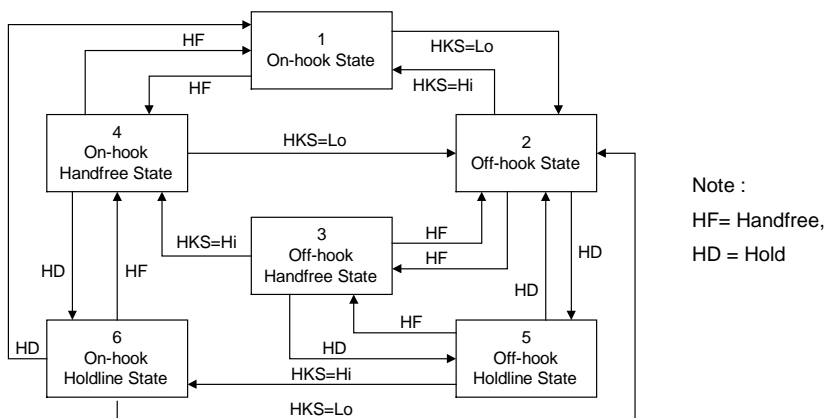

Truth table

Operating State	Input / Output pin level				
	$\overline{\text{HKS}}$	$\overline{\text{PO}}$	$\overline{\text{XMUTE}}$	HFO	HDO
(0) on-hook, idle state	H	F	F	L	L
(1) Off-hook line	L	F	F	L	L
(2) Off-hook, HF line	L	F	F	H	L
(3) On-hook, HF line	H	F	F	H	L
(4) Off-hook, HD line	L	F	L	L	H
(5) On-hook, HD line	H	F	L	L	H

Note : F = floating (high impedance); H = logic "High"; L = logic "Low" level.

G) Music on Hold

SC91415 series built-in a melody generator to generate dual-tone music on DTMF output pin. The music is designed for telephone line at line holding.

H) SDO (Serial Data Output) function

The SDO is serial data output which format is same as UART protocol. SDO function is designed to drive LCD driver and voice synthesizer. So the dialing numbers can be display on LCD screen with SC32100 (or SC32116). The SDO signal consists of two start bits, six data bits and two stop bits. Each bit time is about 3.9 ms (256 Hz) and output sequences are following by start bits, data bits (LSB to MSB) and stop bits.



SDO Keypad Encoded table

* Digital key (b5,b4=0,0)

Keypad	Output				Display
	b3	b2	b1	b0	
1	0	0	0	1	1
2	0	0	1	0	2
3	0	0	1	1	3
4	0	1	0	0	4
5	0	1	0	1	5
6	0	1	1	0	6
7	0	1	1	1	7
8	1	0	0	0	8
9	1	0	0	1	9
0	1	0	1	0	0
**)/T	1	0	1	1	L
#	1	1	0	0	J
P	1	1	0	1	P
* / T"	1	1	1	0	H

* Function key (b5,b4=1,0)

Keypad	Output				Display
	b3	b2	b1	b0	
F	1	1	1	1	Clear all display

* Keypad ,SDO format and LCD display reference table:

Keypad	Bit5	Bit4	Bit3	Bit2	Bit1	Bit0	Display
1	0	0	0	0	0	1	1
2	0	0	0	0	1	0	2
3	0	0	0	0	1	1	3
4	0	0	0	1	0	0	4
5	0	0	0	1	0	1	5
6	0	0	0	1	1	0	6
7	0	0	0	1	1	1	7
8	0	0	1	0	0	0	8
9	0	0	1	0	0	1	9
0	0	0	1	0	1	0	0
**)/T	0	0	1	0	1	1	L
#	0	0	1	1	0	0	J
P	0	0	1	1	0	1	P
* / T"	0	0	1	1	1	0	H
F	1	0	1	1	1	1	Clear all display

I) LOCK function

The SC91415 series provide the LOCK function to inhibit toll dialing operation. Connecting a resistor on COL1 pin to VSS can select different LOCK control method that is conventional key lock or password lock. Also the lock number that can be selected by connecting the resistors on COL2 or COL3 pin. After power on reset, the password is fixed to 000 automatically. The lock function is disabled when the password is equal to 000.

How to setup password

- * Set LOCK function to password control mode. (Connects a resistor on COL1 pin to VSS)
- * Off hook (or turn on HF function)
- * Push: # , # , ops1, ops2, ops3, nps1, nps2, nps3, # . If the ops1~ops3 are the same with current password, then nps1~nps3 will be stored in the dialer to replace current password. Otherwise, the current password can not be updated. All the numbers pressed in the password setup procedure can not be dialed out when current password is not equal to 000. If the current password are equal to 000, then only the first number “#” will be dialed out.

Normal dialing

Set lock function to none lock mode (without resistor connected to COL1 pin) or set password equal to 000. In this case, the dialer is operated in normal mode and all functions work at unlimitation.

Dialing via LOCK function

Conventional key lock mode. (Connects a resistor on COL1 pin to VDD)

- * Off hook (or turn on HF function)
- * Keying: d1, d2, .. , dn . If the first number (d1) is the same with the lock number that optioned in table, then all entry numbers can not be dialed out and keyboard will be inhibited until on to off hook once again. If the first number is not equal to lock number, all the entry numbers will be dialed out.

Password control mode. (Connects a resistor on COL1 pin to VSS)

- * Off hook (or turn on HF function)
- * Keying: ([# , ps1, ps2, ps3] + telephone number.) The numbers in the [] symbol could be omitted. The number “#” will be inhibited when the current password is not equal to 000, and ps1, ps2, ps3 work at the checking state, not to be dialed out. Other descriptions are as on following:

Incorrect password entry. The telephone numbers can not be dialed out.

Password is omitted. If the first digit of telephone numbers is the same with the lock number, all of the telephone numbers can not be dialed out and keyboard will be inhibited until On to Off hook once again. If the first digit is not equal to the lock number then the telephone numbers will be dialed out entirely.

Correct password entry. The telephone numbers can be dial out no matter what lock number is.

J) Ring detector

The Ring detector is designed to prevent illegal dialing from pocket dialer. Following the procedures (i,ii,iii), this dialer will detect $\overline{\text{DRING}}$ pin to control $\overline{\text{RMUTE}}$ output level. If $\overline{\text{DRING}}$ is detected a "Low" level, the $\overline{\text{RMUTE}}$ stays "High impedance". If $\overline{\text{DRING}}$ is detected a "High" level, the $\overline{\text{RMUTE}}$ will output "Low" until keyboard entry. In actual application of the $\overline{\text{RMUTE}}$ pin is recommended connection to microphone of the phone handset to prevent that the dialing signal (DTMF) is coupling by the Microphone of the phone handset. (such as pocket dialer)

- i. In idle state, $\overline{\text{HKS}}$ is from "High" to "Low" (pick up handset action).
- ii. In idle state, turn on handfree function.
- iii. The flash operation (F key).

TIMING DIAGRAMS

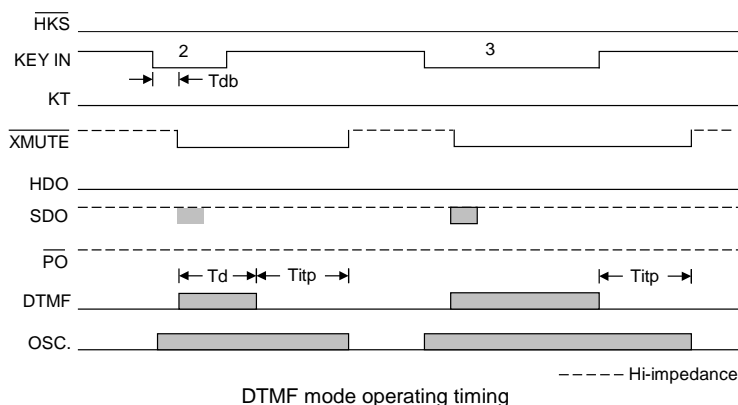
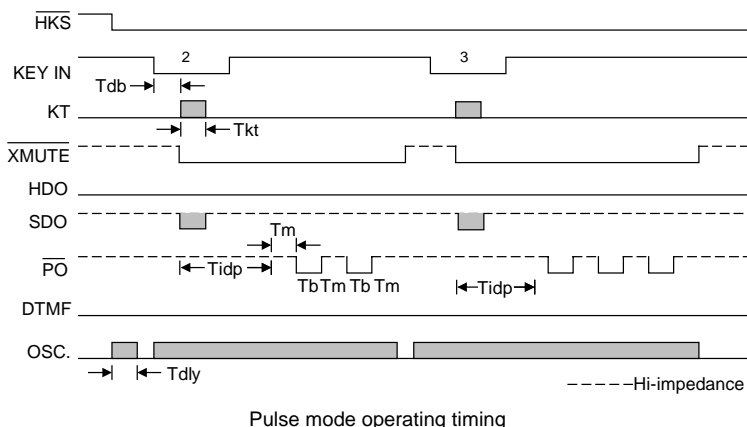

TIMING DIAGRAMS (continued)

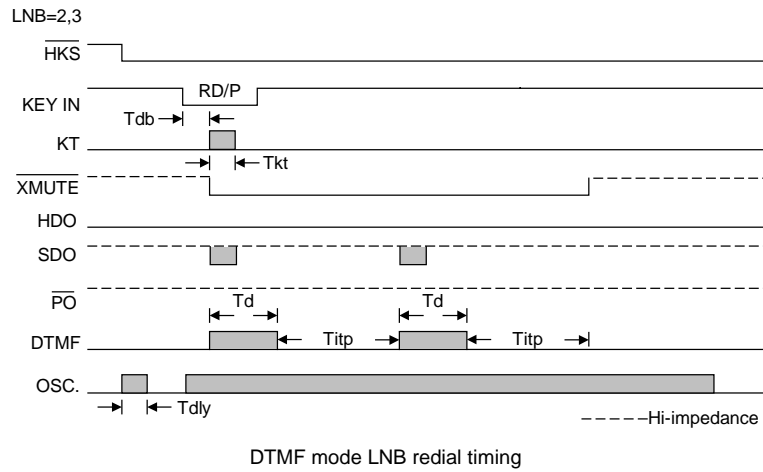
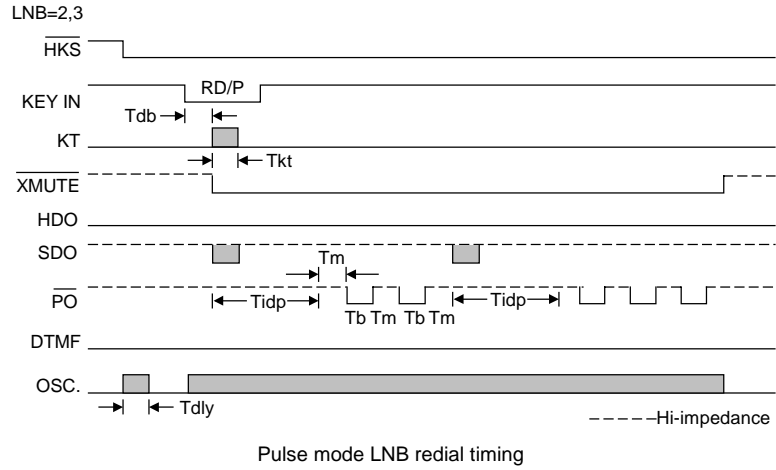

TIMING DIAGRAMS (continued)

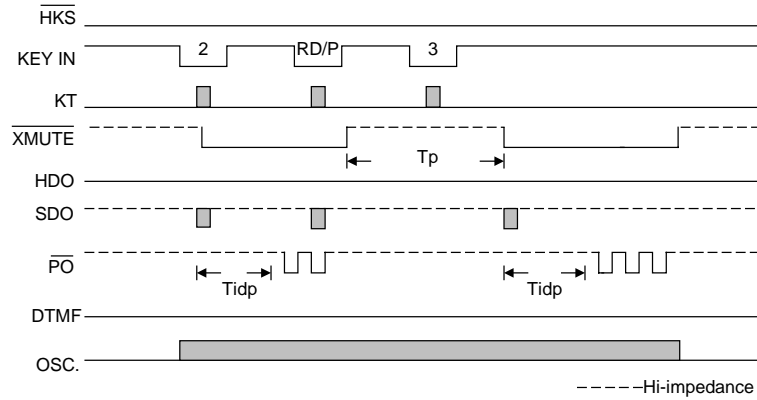

Pause key operating timing

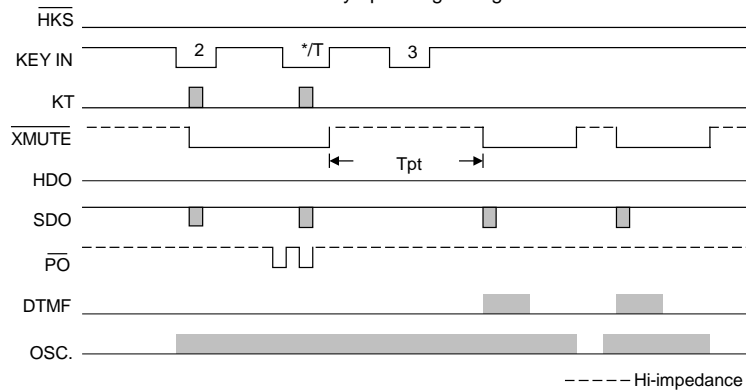

Pulse to Tone (P→T) operating timing

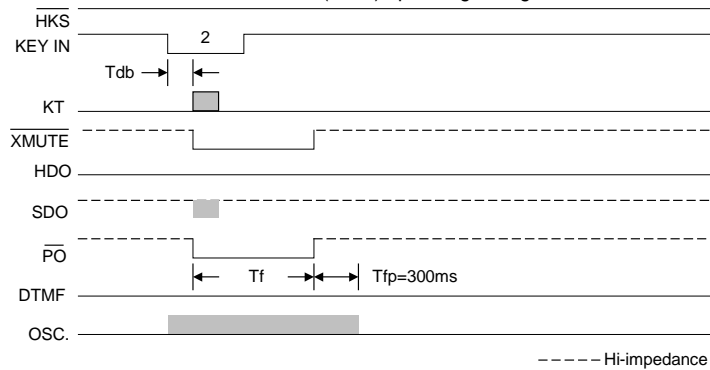

Flash key operating timing

TIMING DIAGRAMS (continued)

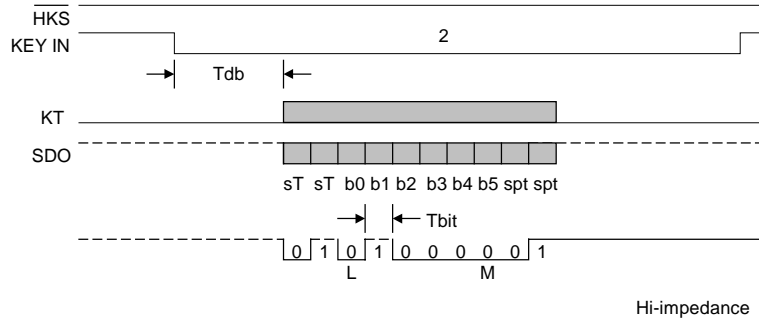

Note: L=LSB, M=MSB, sT=START bit time, spT=STOP bit time

SDO operating timing

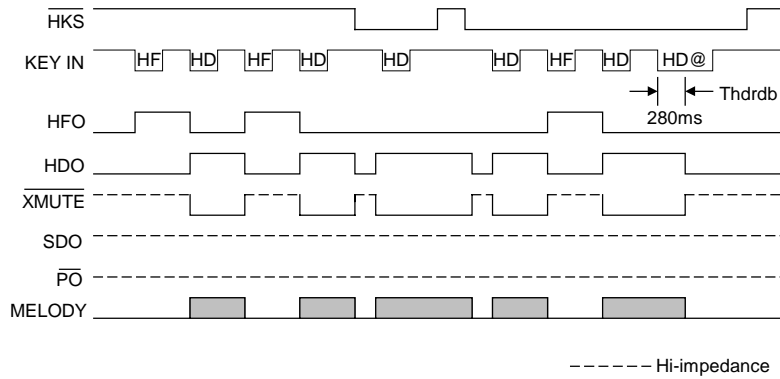

@ :It can be triggered by extension telephone set for hold function release

HF and HD operating timing

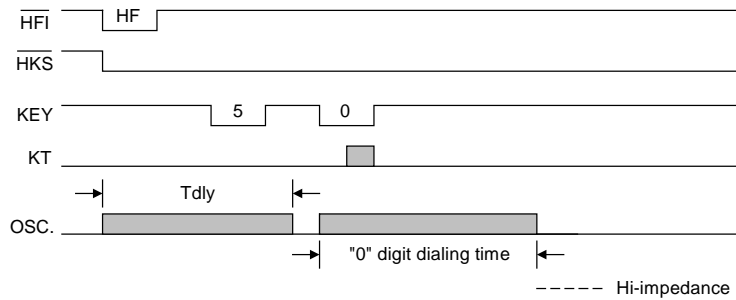

Off-Hook delay time

TIMING DIAGRAMS (continued)

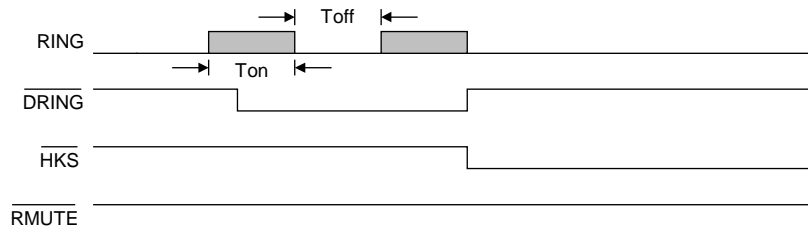

Timing of receiving an incoming call

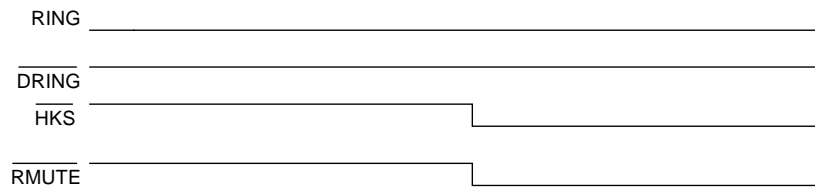

Timing of making an outgoing call

TYPICAL APPLICATION CIRCUIT (for SC91415)

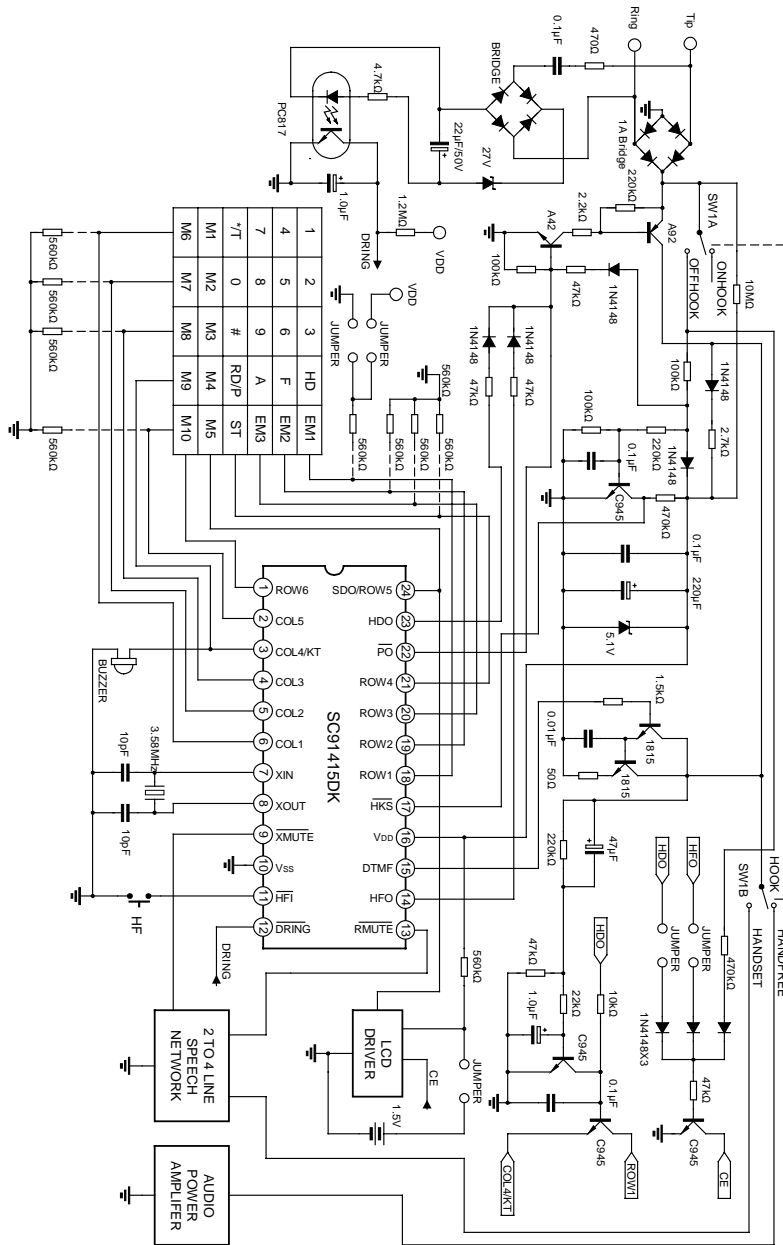

CHIP TOPOGRAPHY

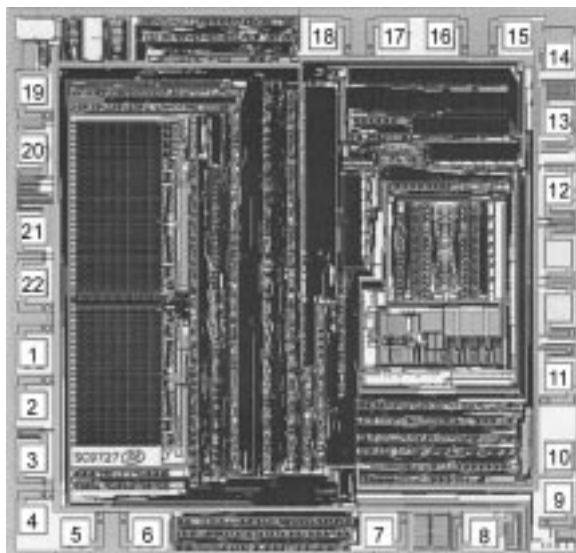

Size: 2.16 x 2.33 mm²

PAD COORDINATES (Unit: μm)

No.	Symbol	X	Y	No.	Symbol	X	Y
1	P1	-1002.4	-256.3	12	P12	1006.5	350.1
2	P2	-1002.4	-450.7	13	P13	1006.5	608.3
3	P3	-1002.4	-649.1	14	P14	1007.2	846.3
4	P4	-1002.4	-878.2	15	P15	849.2	923.4
5	P5	-839.9	-925.4	16	P16	556.0	923.4
6	P6	-563.3	-925.4	17	P17	379.6	923.4
7	P7	321.0	-925.4	18	P18	108.0	923.4
8	P8	721.4	-926.5	19	P19	-1002.4	719.1
9	P9	1006.5	-794.9	20	P20	-1002.4	501.8
10	P10	1006.5	-639.7	21	P21	-1001.4	200.2
11	P11	1006.5	-343.1	22	P22	-1002.4	5.1

Note: The original point of the coordinate is the die center.

PACKAGE OUTLINE

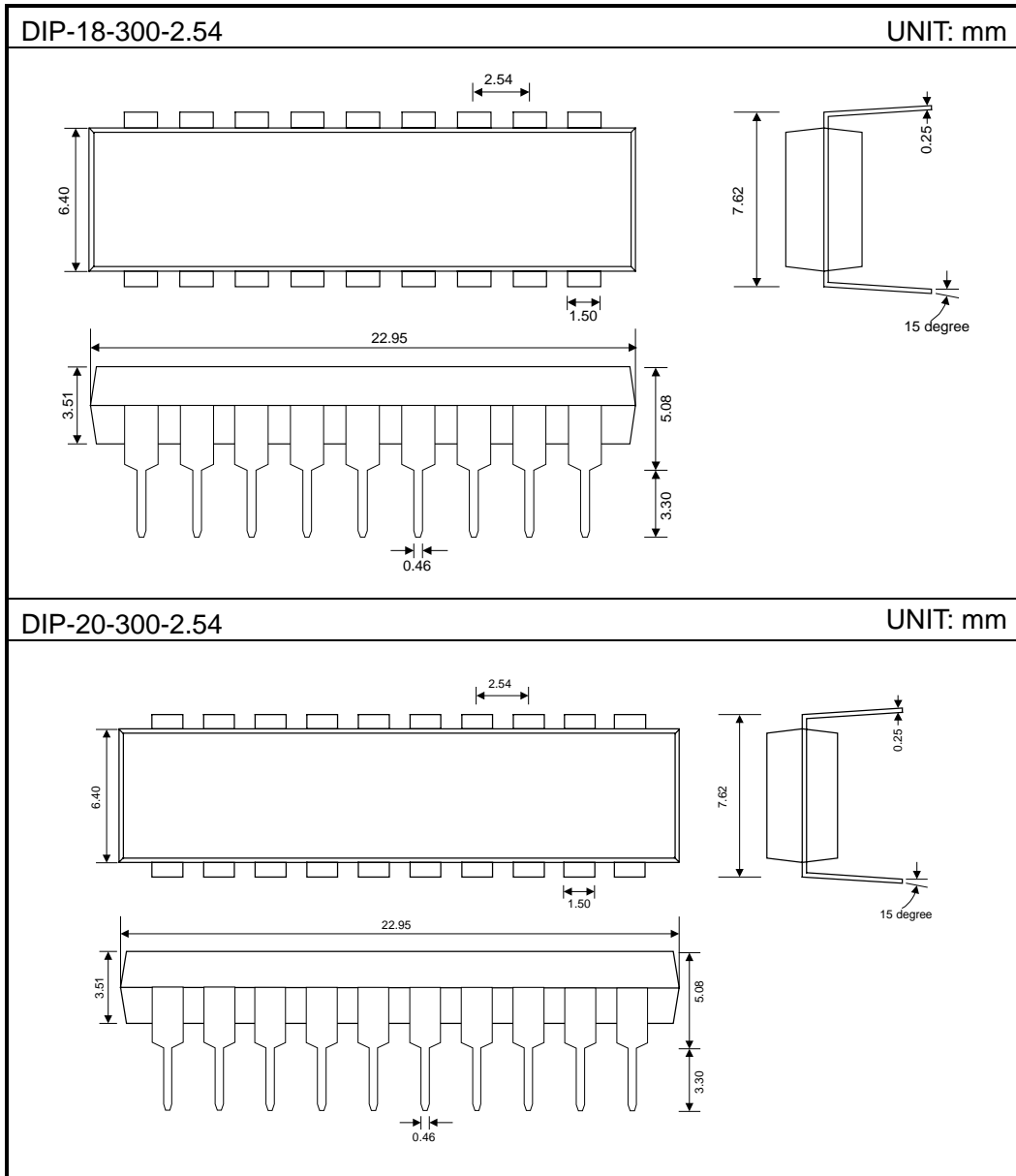

PACKAGE OUTLINE

